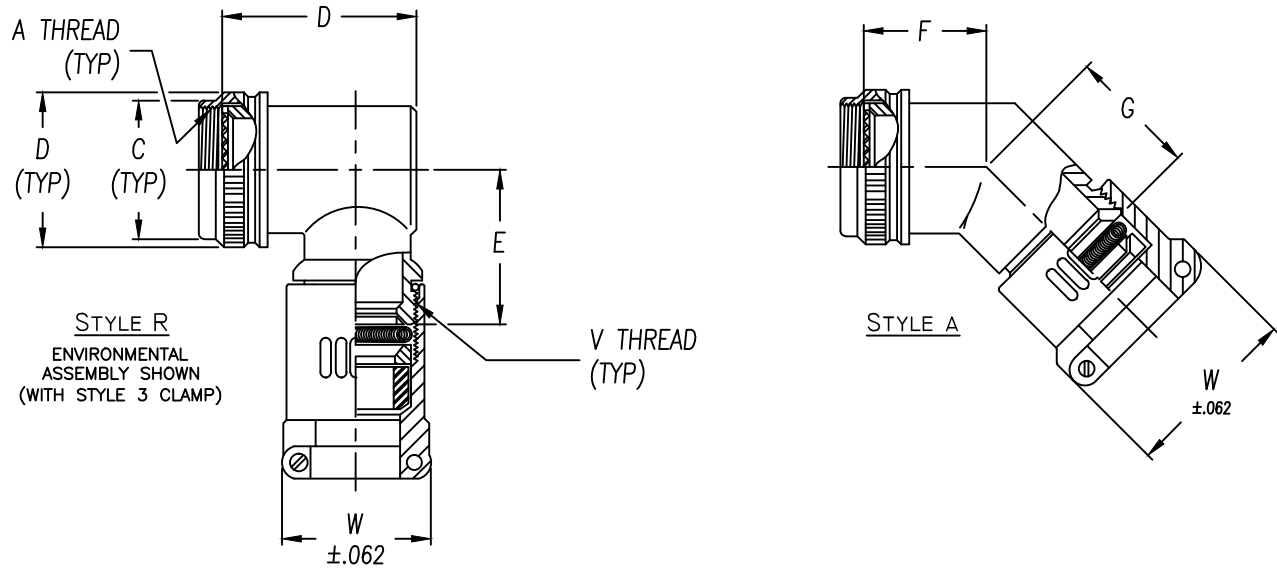




**Table 2 - Cable Entry Data**

ENTRY ORDER NUMBER	ENVIRONMENTAL GLAND RANGE		NON ENVIRONMENTAL CABLE RANGE		V UNIFIED THREAD
	MAX	MIN	MAX	MIN	
03	.250	.156	.250	.156	.500-28
04	.312	.188	.312	.188	.625-24
06	.438	.281	.438	.281	.750-20
08	.562	.375	.562	.344	.875-20
10	.625	.500	.625	.375	1.000-20
12	.750	.500	.750	.438	1.188-18
16	.938	.625	.938	.562	1.438-18
20	1.250	.938	1.250	.750	1.750-18
24	1.375	1.000	1.375	.781	2.000-18
28	1.625	1.250	1.625	.969	2.250-16
32	1.875	1.500	1.875	1.125	2.500-16

WHEN MAXIMUM CABLE ENTRY EXCEEDS THE CONNECTOR INTERFACE DIAMETER, A 2 PIECE ADAPTER WILL BE SUPPLIED.



ASSEMBLY PART NUMBER

TO ESTABLISH YOUR P/N, USE THE FOLLOWING EXAMPLE

**E 41 38 S 23 08 9 B 51**

FUNCTION DESIGNATOR  
 E - EMI ADAPTER

CONNECTOR CODE NUMBER - TABLE 1 (6)

SERIES PART NUMBER

ADAPTER STYLE  
 R = 90° ADAPTER  
 A = 45° ADAPTER

ACCESSORY ORDER NUMBER-TABLE 1

MOD CODE (6)

PLATING CODE NUMBER-TABLE 4 (6)

GLAND & O-RING MATERIAL OPTION  
 B - NEOPRENE & BUNA-N  
 S - SILICONE  
 N - NONE REQUIRED (NON ENVIROMENTAL)

CABLE STRAIN-TABLE V (8)

CABLE ENTRY ORDER NUMBER-TABLE 2



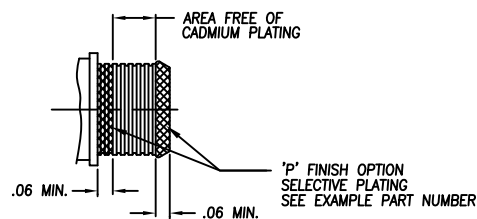


**STANDARD FINISHES**

PLATING CODE	FINISH	SPECIFICATION	ACCESSORY MATERIAL	CORROSION RESISTANCE (HRS)	ROHS COMPLIANT
0 3	CADIUM PLATE, OLIVE DRAB	SAE AMS-QQ-P-416, TYPE II, CLASS 3	ALUMINUM	96	NO
1 0	PASSIVATE	SAE AMS-QQ-P-35, (AS85049 CODE S)	STAINLESS STEEL	1000	YES
1 2	ZINC NICKEL, BLACK	ASTM B841	ALUMINUM	500	YES
1 3	ZINC COBALT, OLIVE DRAB	ASTM B840-99	ALUMINUM	96	NO
1 4	ZINC COBALT, BLACK	ASTM B840-99	ALUMINUM	96	NO
2 1	IRIDITE, 14-2, GOLD	IRIDITE, NUMBER 14-2 PER MIL-DTL-5541 CL 3	ALUMINUM	96	NO
3 4	ANODIZE, BLACK	MIL-A-8625, TYPE II, CL 3 (AS85049 CODE A)	ALUMINUM	1000	YES
3 5	ANODIZE ,GREY	MIL-A-8625, TYPE II, CLASS 2	ALUMINUM	500	YES
4 4	ANODIZE, HARD, BLACK	MIL-A-8625, TYPE II, CLASS 2	ALUMINUM	500	YES
4 5	ANODIZE, HARD, GREY	MIL-A-8625, TYPE II, CLASS 2	ALUMINUM	1000	YES
4 8	ELECTROLESS NICKEL	AMS-2404F, CLASS 4, GRADE B	STAINLESS STEEL	48	NO
5 1	ELECTROLESS NICKEL	AMS-2404F, CLASS 4, GRADE B	ALUMINUM	48	NO
5 5	CADIUM PLATE, OLIVE DRAB, OVER ELECTROLESS NICKEL	SAE AMS-QQ-P-416, TYPE II, CLASS 3, OVER ELECTROLESS NICKEL, PER AMS-2404F (AS85049 CODE W)	ALUMINUM	1000	NO
5 6	ELECTROLESS NICKEL	AMS-2404F, CLASS 4, GRADE A	ALUMINUM	96	NO
5 6 R	ELECTROLESS NICKEL	AMS-2404F, CLASS 4, GRADE A	ALUMINUM	48	YES
5 7	ELECTROLESS NICKEL	AMS-2404F, CLASS 4, GRADE A (AS85049 CODE N)	ALUMINUM	96	NO
64	CADIUM PLATE, OLIVE DRAB, OVER ELECTROLESS NICKEL	SAE AMS-QQ-P-416, TYPE II, CLASS 3, OVER  ELECTROLESS NICKEL, PER AMS-2404F (SELECTIVE PLATING REF AS85049 CODE P)	ALUMINUM	1000	NO
85	PASSIVATED	SAE AMS-QQ-P-35	316 SST	1000	YES
87	BEAD BLASTED	N/A	NI. ALUM. BRONZE	1000	YES

NOTES: UNLESS OTHERWISE SPECIFIED

1. CORROSION RESISTANCE IS SPECIFIED FOR SALT SPRAY IN ACCORDANCE WITH AS85049
- CONSULT FACTORY FOR OTHER FINISHES
- FINISHES ARE APPLICABLE TO THE CONNECTOR ACCESSORIES ONLY AND EXCLUDE FASTENERS AND OTHER HARDWARE
4. EMI/RFI ACCESSORIES ARE SUPPLIED WITH CONDUCTIVE FINISHES ONLY
5. ANODIZE NOT SUITABLE FOR EMI SHIELDING OR GROUNDING APPLICATIONS
6. ALL THE CONDUCTIVE FINISHES USED ON ALUMINUM CAN ALSO BE USED ON BRASS (CONSULT FACTORY)
- CADMIUM/NICKEL INTERFACE SHALL BE COATED WITH POLYSULFIDE SEALANT (REF FIGURE 2 BELOW)



**FIGURE 2**



**STANDARD MATERIALS**

COMPONENT	MATERIAL	SPECIFICATION
MACHINED COMPONENTS	ALUMINUM STAINLESS STEEL (300 SERIES) BRASS NICKEL ALUMINUM BRONZE	ASTM B221, ASTM B211 (MFG OPTION) AMS-QQ-S-763, QQ-S-764 (MFG OPTION) QQ-B-626 ASTMB150 (AMS4640)
DIE CAST COMPONENTS	ALUMINUM	ASTM B 85
FASTENERS AND HARDWARE	STAINLESS STEEL (300 SERIES) STEEL BRASS	AMS-QQ-S-763 SAE20, QQ-S-634, QQ-S-637 QQ-B-626
ELASTOMERIC SEALS	SILICONE BUNA-N NEOPRENE	ZZ-R-765B, MIL-R-25988 AMS-3209 MIL-R-3065

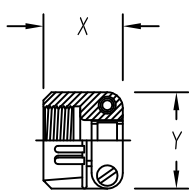
NOTES: UNLESS OTHERWISE SPECIFIED

1. THE SPECIFIED MATERIALS ARE STANDARD FOR THE MAJORITY OF CONNECTOR ACCESSORIES
2. CONSULT FACTORY FOR OTHER MATERIALS
3. FOR DOCUMENTS LISTED WITHIN THIS CATALOG WITH OUT A TOLERANCE SHOWN SHALL HAVE TOLERANCES AS FALLOWED:
  - .X =  $\pm .2$
  - .XX =  $\pm .12$
  - .XXX =  $\pm .062$
  - X° =  $\pm 10^\circ$

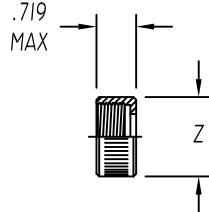


**Table 2 - Environmental / Non-Environmental Cable Entry Data**

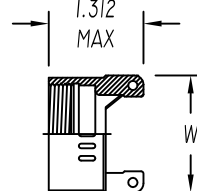
ENTRY ORDER NUMBER	ENVIRONMENTAL		NON ENVIRONMENTAL		V UNIFIED THREAD	R MAX DIM.	S MAX DIM.	T MAX DIM.	U MAX DIM.	W MAX DIM.	X MAX DIM.	Y MAX DIM.	Z MAX DIA.
	GLAND RANGE		CABLE RANGE										
	MAX	MIN	MAX	MIN									
△ 03	.250	.156	.250	.156	.500-28	N / A	.812	1.375	.812	N / A	.844	.781	.656
04	.312	.188	.312	.188	.625-24	1.031	.937	1.375	.937	.875	.844	.906	.781
06	.438	.281	.438	.281	.750-20	1.031	1.062	1.375	1.062	1.000	.906	1.094	.906
08	.562	.375	.562	.344	.875-20	1.031	1.188	1.375	1.188	1.125	.969	1.188	1.031
10	.625	.500	.625	.375	1.000-20	1.094	1.312	1.437	1.312	1.250	.969	1.281	1.156
12	.750	.500	.750	.438	1.188-18	1.219	1.562	1.437	1.562	1.375	.969	1.500	1.344
△ 14	.875	.750	.875	.719	1.250-18	N / A	N / A	N / A	N / A	1.500	N / A	N / A	N / A
16	1.000	.844	1.000	.781	1.438-18	1.219	1.750	1.562	1.750	1.625	1.062	1.719	1.594
20	1.250	.938	1.250	.750	1.750-18	1.344	2.250	1.812	2.250	1.750	1.125	2.062	1.906
24	1.375	1.000	1.375	.781	2.000-18	N / A	2.375	2.062	2.375	N / A	1.188	2.312	2.156
28	1.625	1.250	1.625	.969	2.250-16	N / A	2.625	2.062	2.625	N / A	1.719	2.719	2.406
32	1.875	1.500	1.875	1.125	2.500-16	N / A	2.812	2.188	2.812	N / A	1.781	2.969	2.656



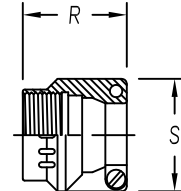
**STYLE 1** △  
 AS85049/41A CLAMP  
 (MS 3057\*\*A)



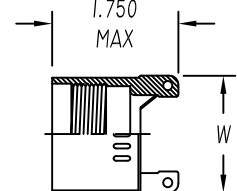
**STYLE 2** △  
 NUT



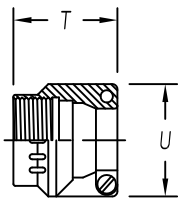
**STYLE 3** △  
 NON-ENVIRONMENTAL



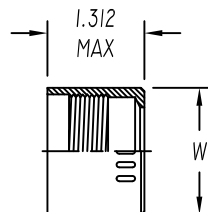
**STYLE 3** △  
 NUT ENVIRONMENTAL  
 (AS85049/1)  
 (MS 3057-\*\*B)



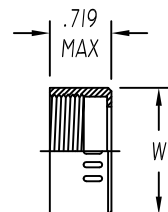
**STYLE 3** △  
 ENVIRONMENTAL



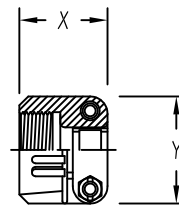
**STYLE 4** △  
 STRAIN RELIEF ENVIRONMENTAL  
 (AS85049/2)  
 (MS 3057-\*\*C)



**STYLE 4** △  
 ENVIRONMENTAL



**STYLE 4** △  
 NON-ENVIRONMENTAL



**STYLE 9** △  
 STRAIN-RELIEF CLAMP WITH TELESCOPING SCREWS

NOTES: UNLESS OTHERWISE SPECIFIED

△1 AVAILABLE ONLY ON: A\*\*01, A\*\*30, E\*\*01, E\*\*03, E\*\*04, E\*\*05, E\*\*07, E\*\*21, E\*\*30, & E\*\*33

△2 AVAILABLE ONLY ON: E\*\*15, E\*\*17, E\*\*38, E\*\*40, & E\*\*41

3. CONSULT FACTORY FOR SIZES AND INFORMATION NOT LISTED